

Investor Visit to Stadco, October 11<sup>th</sup> 2006

# Stadco – an overview



Introduction



History



Our Company



Quality  
& Delivery



Facilities



Technology  
& Capabilities



Case Studies



**STADCO**

Investor Visit to Stadco, October 11th 2006

# Agenda

- Introduction to Stadco
- Outsourcing of Body Components
- Stadco Facilities
- Future Development



Introduction



History



Our Company



Quality  
& Delivery



Facilities



Technology  
& Capabilities



Case Studies



**STADCO**

Investor Visit to Stadco, October 11th 2006

# Agenda

- Introduction to Stadco
- Outsourcing of Body Components
- Stadco Facilities
- Future Development



Introduction



History



Our Company



Quality  
& Delivery



Facilities



Technology  
& Capabilities



Case Studies



**STADCO**

Introduction

# Who we are

Stadco is a Tier 1 supplier of automotive Body-in-White products and services.

Core capabilities are aluminium and steel pressings, assemblies and product and facility design.

Solutions from niche to high volume are provided.



Introduction



History



Our Company



Quality & Delivery



Facilities



Technology & Capabilities



Case Studies



STADCO

Introduction

# What we do

Pressings, Assemblies & Product Engineering  
for the Automotive Industry



High volume



Medium volume



Low volume



Introduction



History



Our Company



Quality  
& Delivery



Facilities



Technology  
& Capabilities



Case Studies



STADCO

Introduction

# Complete life cycle service

Focusing on our core competence in Body-In-White, we are able to support our customers throughout the complete model cycle of a vehicle

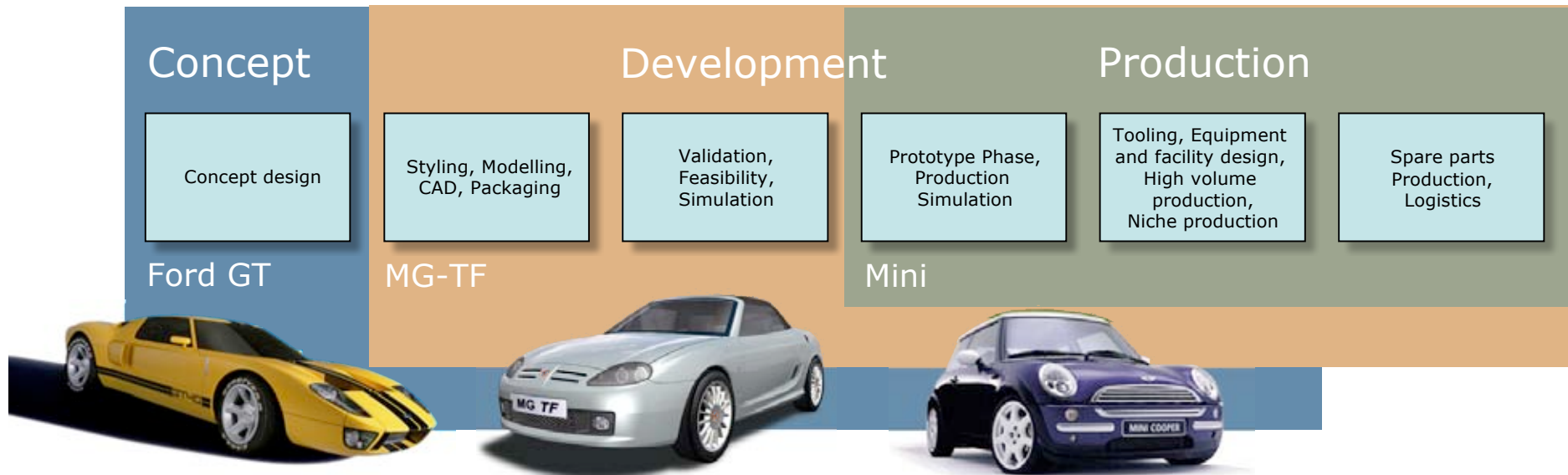

Introduction



History



Our Company



Quality & Delivery



Facilities



Technology & Capabilities



Case Studies



STADCO

Our Company

# Our product



Aluminium pressings

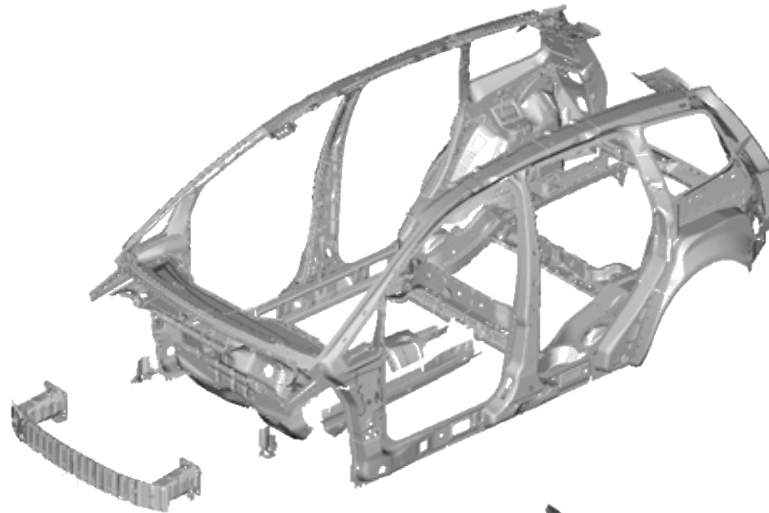

High volume assemblies

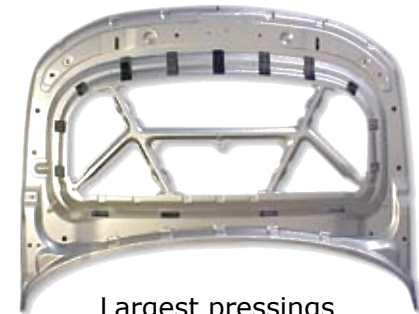

Largest pressings up to 4m



Small pressings & in-process fixturing



Low volume manual assemblies

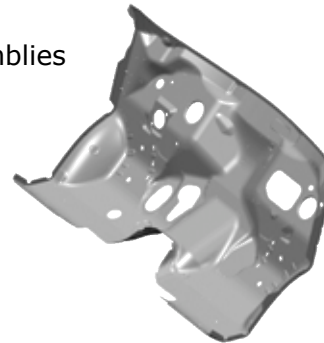

Steel pressings



Complete Body-in-White



Introduction



History



Our Company



Quality & Delivery



Facilities



Technology & Capabilities



Case Studies



STADCO

Our Company

# Our partnerships



Introduction



History



Our Company



Quality & Delivery



Facilities



Technology & Capabilities



Case Studies



STADCO

Our Company

# Global customers include



**HONDA**



Introduction



History



Our Company



Quality & Delivery



Facilities



Technology & Capabilities



Case Studies



**STADCO**

Our Company

# Sales by customer

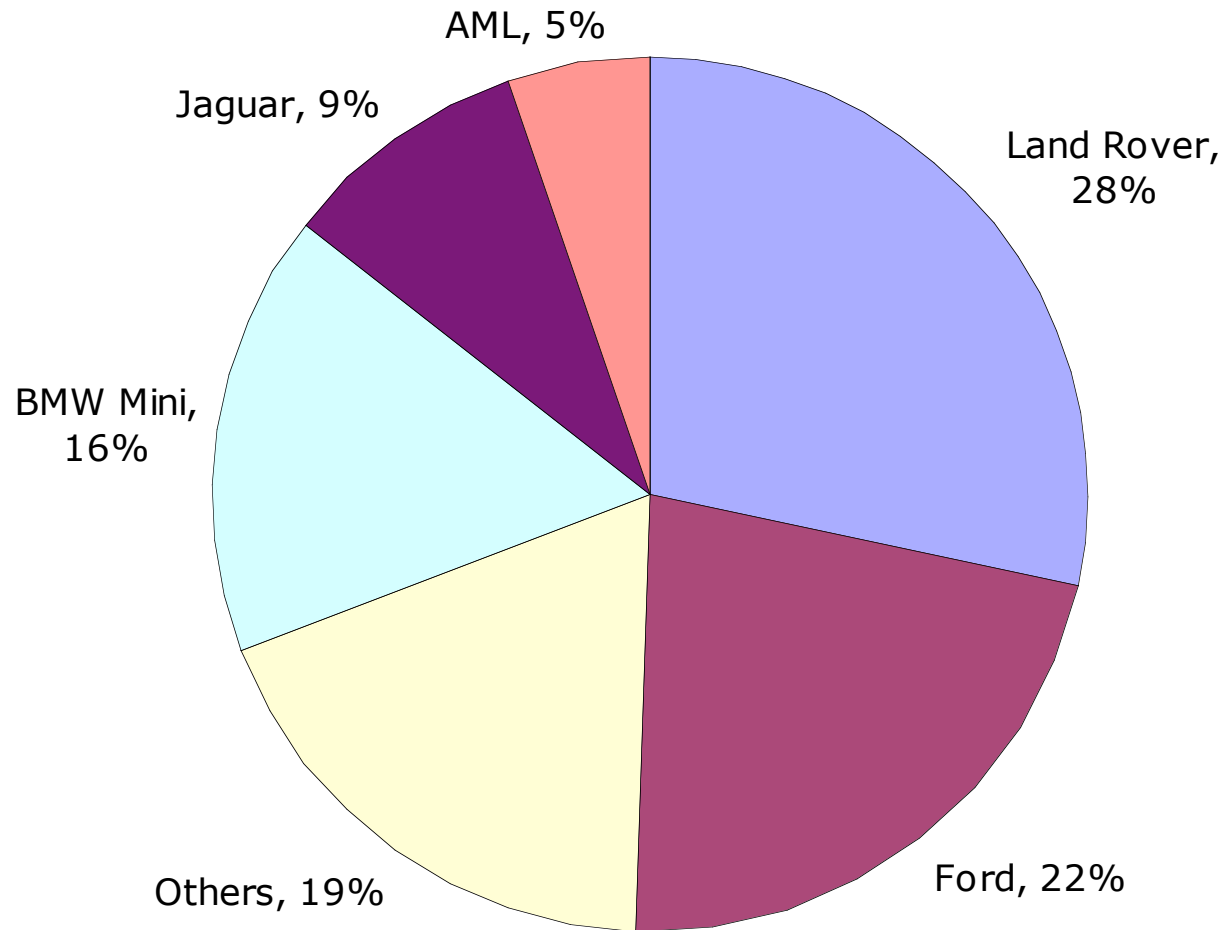

Introduction



History



Our Company



Quality  
& Delivery



Facilities



Technology  
& Capabilities



Case Studies



STADCO

Capabilities

# Project & launch management

A proven track record

Typical Stadco responsibilities;

- Support product design
- Lead design of tools
- Lead prototype production
- Lead quality approval
- Support vehicle build



**BV256 Project**  
455 Tools, 48 Major Assemblies



Introduction



History



Our Company



Quality  
& Delivery



Facilities



Technology  
& Capabilities



Case Studies



**STADCO**

History

# Early years

**1812**

John Hall started a business dealing in metals, particularly iron.

**1858**

Samuel Chatwood produced his first safe from the Bolton Lock & Safe Company in Lancashire.

**1902**

Samuel Chatwood died and the Hall family bought a controlling interest in the business.

**1915**

The Chatwood Safe Company was acquired by the Hall family.



Introduction



History



Our Company



Quality  
& Delivery



Facilities



Technology  
& Capabilities



Case Studies



STADCO

# Recent progress

## 2003

Stadco acquired a 33,000 square metre body shop in Southwest Germany, located adjacent to Ford's Saarlouis assembly plant.

A joint venture is formed with LDV to operate a large press shop, later to become Stadco Birmingham.

## 2004

Stadco acquires Parker Tools, a specialist manufacturer of press tooling and equipment.

Stadco acquired the assets of Mayflower Vehicle Systems and renames the two MVS plants Stadco Coventry and Stadco Castle Bromwich.



Introduction



History



Our Company



Quality & Delivery



Facilities



Technology & Capabilities



Case Studies



STADCO

Investor Visit to Stadco, October 11th 2006

# Agenda

- Introduction to Stadco
- Outsourcing of Body Components
- Stadco Facilities
- Future Development



Introduction



History



Our Company



Quality  
& Delivery



Facilities



Technology  
& Capabilities



Case Studies



**STADCO**

# History of outsourcing

Outsourcing of components and systems was initiated by the Japanese in the post-war years.

Later, U.S. and European OEMs followed suit, driven by the need to reduce costs

Early outsourced systems included seating, chassis modules etc. Body components and sub-assemblies are now following, as the OEMs continued to reduce headcount and maximise facility efficiency.



Introduction



History



Our Company



Quality  
& Delivery



Facilities



Technology  
& Capabilities



Case Studies



STADCO

# Economics of outsourcing - Pressings

- Reduce wage costs by up to 30%.
- More efficient use of facilities :-

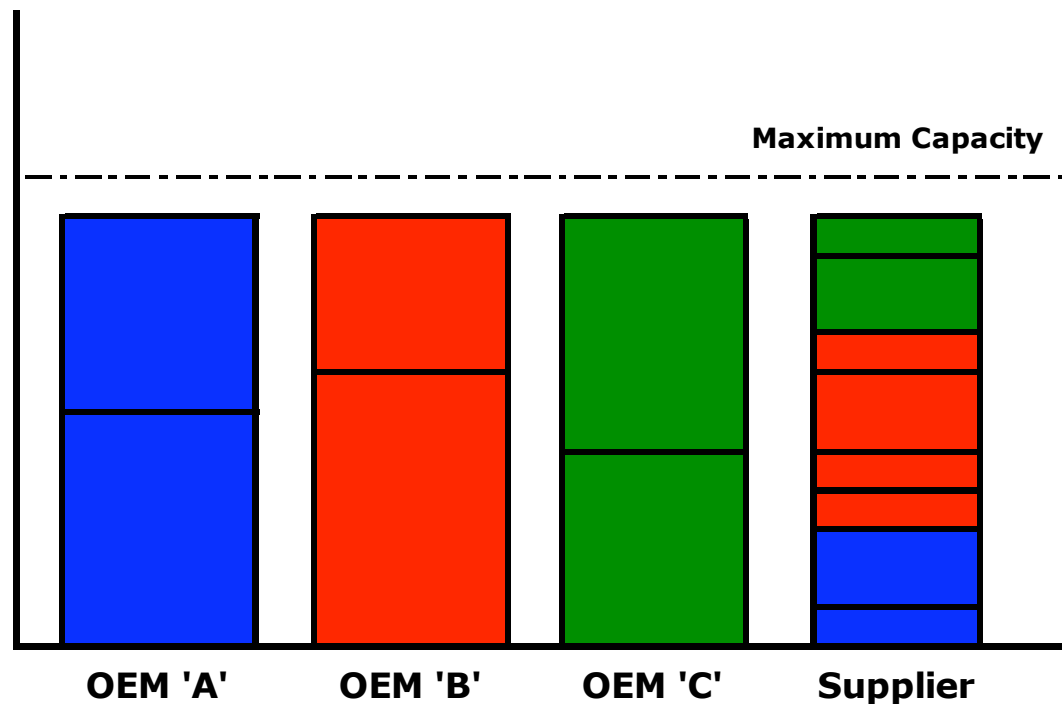

Introduction



History



Our Company



Quality  
& Delivery



Facilities



Technology  
& Capabilities



Case Studies



STADCO

# Economics of outsourcing - Assemblies

- Lower wage costs
- Space requirements at OEMs, reduce associated investments
- As the outsourcing model has matured, technological capability is passing to the supply base – e.g. flexible assembly cells.
- Stadco can now implement facilities at lower cost – up to 40%.



Introduction



History



Our Company



Quality  
& Delivery



Facilities



Technology  
& Capabilities



Case Studies



STADCO

# Growth of outsourcing will continue

- The trend for multi variants off the same platform will continue, e.g Beetle/Golf/TT/Touran/Eos/Leon/Roomster. This drives assembly space constraints at the OEMs
- Many variants at smaller volumes increases the press capacity requirement
- Plant closures, reduced capacity in OEMs



Introduction



History



Our Company



Quality  
& Delivery



Facilities



Technology  
& Capabilities



Case Studies



STADCO

# Who is involved

- The OEMs – still our competitors whilst 70% plus remains in-house in Europe
- Stadco
- Wagon
- Tower
- Thyssen-Krupp
- Japanese suppliers for the transplants
- Gedia
- Kirchoff



Introduction



History



Our Company



Quality  
& Delivery



Facilities



Technology  
& Capabilities



Case Studies



**STADCO**

Investor Visit to Stadco, October 11th 2006

# Agenda

- Introduction to Stadco
- Outsourcing of Body Components
- **Stadco Facilities**
- Future Development



Introduction



History



Our Company



Quality  
& Delivery



Facilities



Technology  
& Capabilities



Case Studies



**STADCO**

Our Company

# Locations

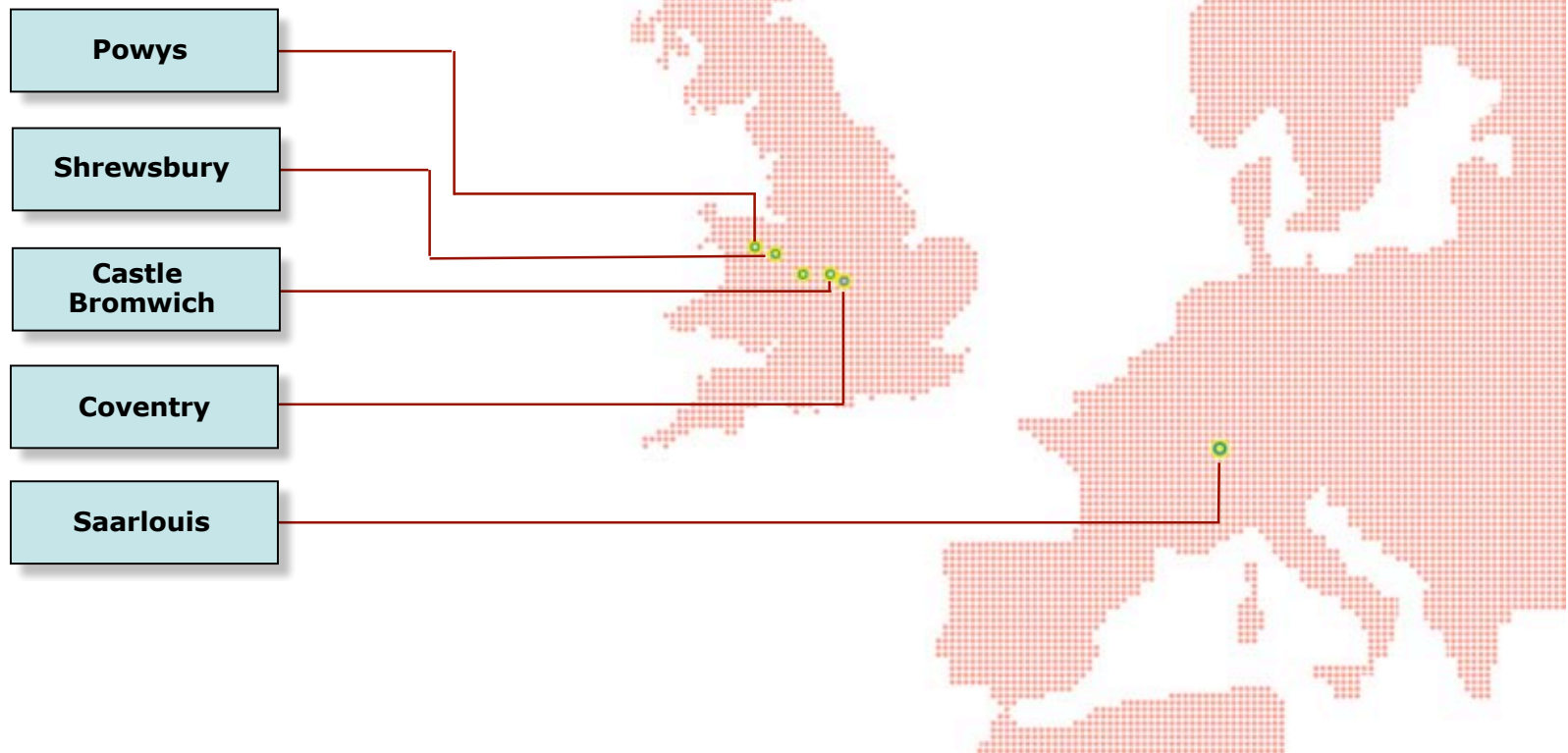

Introduction



History



Our Company



Quality & Delivery



Facilities



Technology & Capabilities



Case Studies



**STADCO**

Facilities

# Castle Bromwich



Introduction



History



Our Company



Quality  
& Delivery



Facilities



Technology  
& Capabilities



Case Studies



**STADCO**

Facilities

# Coventry

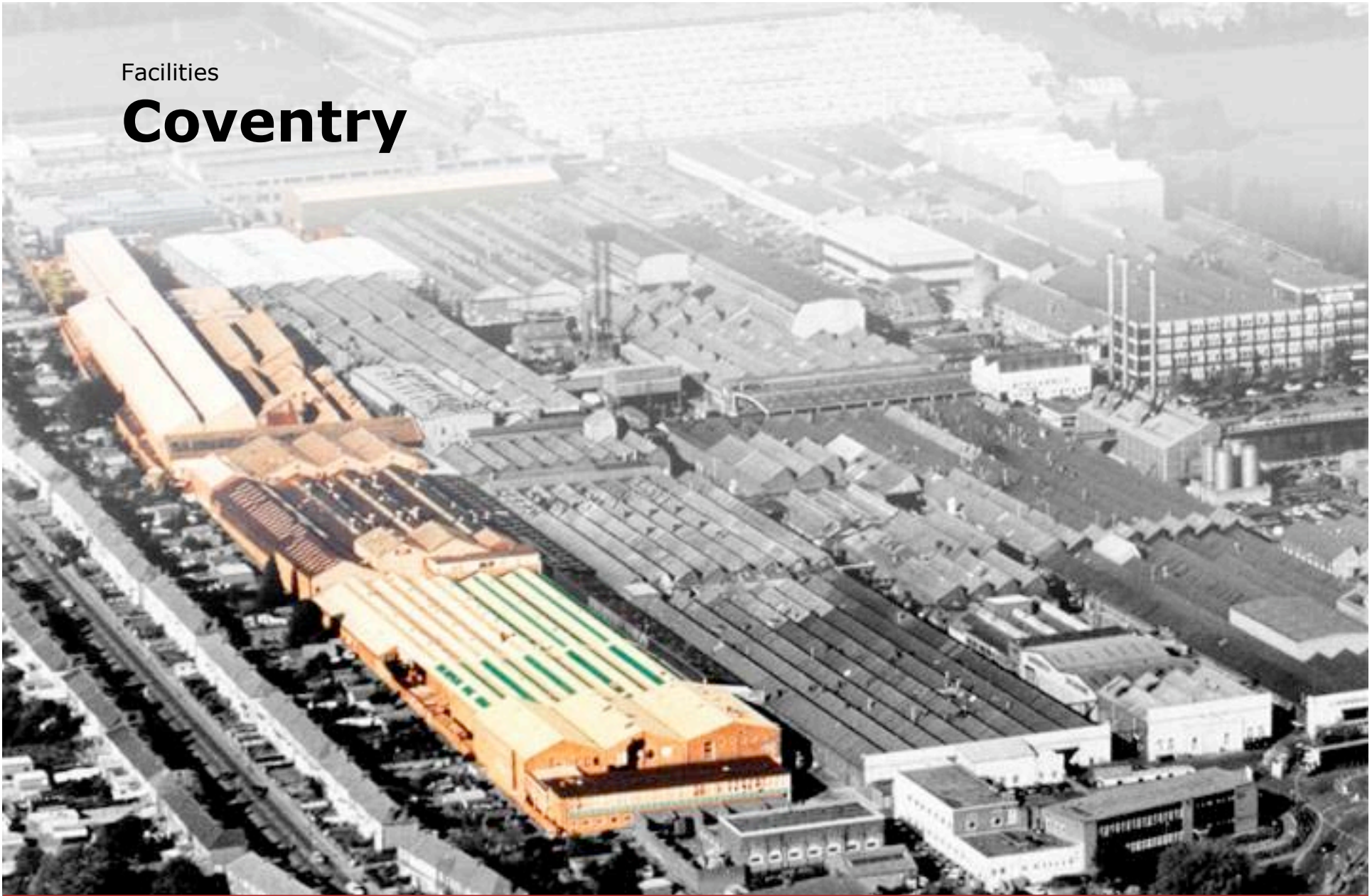

Introduction



History



Our Company



Quality  
& Delivery



Facilities



Technology  
& Capabilities



Case Studies



**STADCO**

Facilities

# Powys



Introduction



History



Our Company



Quality  
& Delivery



Facilities



Technology  
& Capabilities



Case Studies



**STADCO**

Facilities

# Saarlouis



Introduction



History



Our Company



Quality  
& Delivery



Facilities



Technology  
& Capabilities



Case Studies



**STADCO**

Facilities

# Shrewsbury



Introduction



History



Our Company



Quality  
& Delivery



Facilities



Technology  
& Capabilities



Case Studies



**STADCO**

Facilities

# Overview



Plant	Comments
Castle Bromwich	Very large parts, skin panels
Coventry	Low volume, painting, prototyping
Powys	Low volume, painting, aftermarket
Saarlouis	High volume assemblies for Ford
Shrewsbury	High volume main pressings centre



Introduction



History



Our Company



Quality  
& Delivery



Facilities



Technology  
& Capabilities



Case Studies



STADCO

# Post MG Rover

- Closure of Tipton and downsizing of Coventry
- Consolidation of Halewood into Shrewsbury
- Remaining free capacity across the group is c. 20%



Introduction



History



Our Company



Quality  
& Delivery



Facilities



Technology  
& Capabilities



Case Studies



STADCO

Investor Visit to Stadco, October 11th 2006

# Agenda

- Introduction to Stadco
- Outsourcing of Body Components
- Stadco Facilities
- Future development



Introduction



History



Our Company



Quality  
& Delivery



Facilities



Technology  
& Capabilities



Case Studies



**STADCO**

Investor Visit to Stadco, October 11th 2006

# Agenda

- Introduction to Stadco
- Outsourcing of Body Components
- Stadco Facilities
- Future development
  - New platforms
  - New markets



Introduction



History



Our Company



Quality  
& Delivery



Facilities



Technology  
& Capabilities



Case Studies



STADCO

# Development

- New Platforms
  - New Mini
  - New XK
  - New Freelander
  - New Focus 'Off-road'
  - New Transit
  - Re-launched MGTF



Introduction



History



Our Company



Quality  
& Delivery



Facilities



Technology  
& Capabilities



Case Studies



STADCO

# Development, new markets

- Russia
  - We are currently in wide ranging discussions with a number of parties and partners regarding pressings and assemblies.
- Germany
  - Another area of likely growth, we continue to study opportunities



Introduction



History



Our Company



Quality  
& Delivery



Facilities



Technology  
& Capabilities



Case Studies



**STADCO**

# Development, new Markets

- Russia

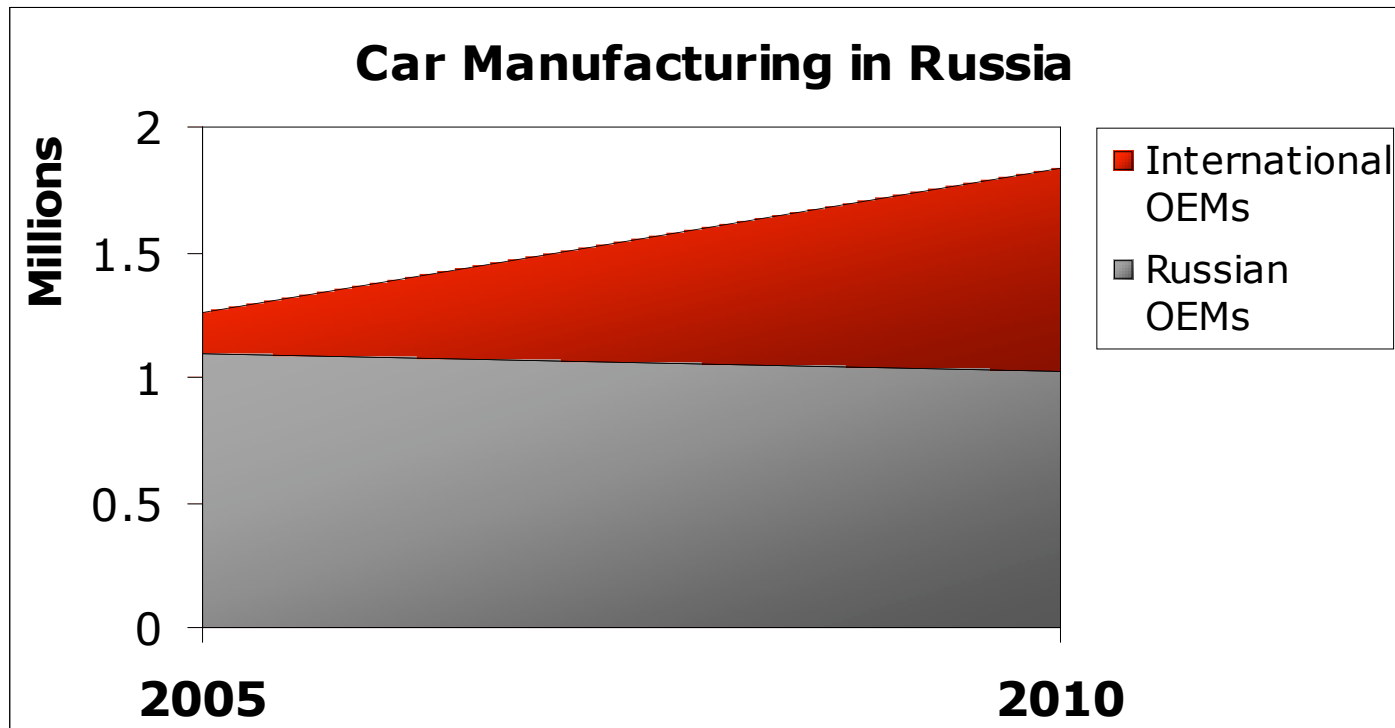

Source : JD Power



Introduction



History



Our Company



Quality  
& Delivery



Facilities



Technology  
& Capabilities



Case Studies



**STADCO**

# Development, new markets

- Russia

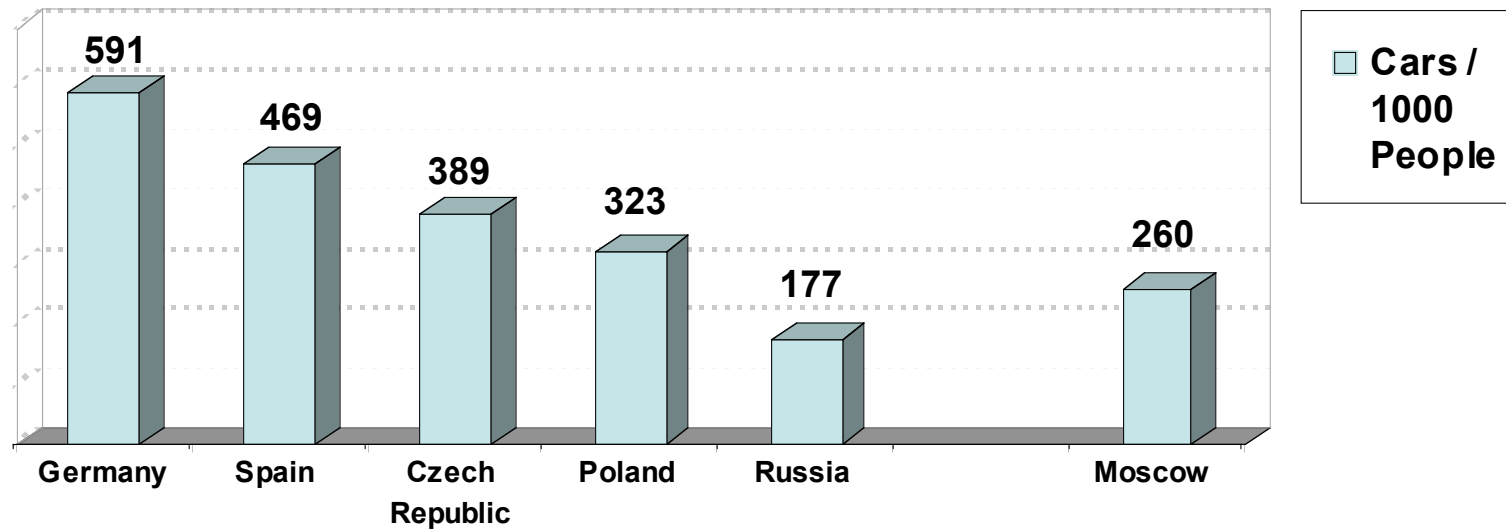

Source : Ernst & Young



Introduction



History



Our Company



Quality  
& Delivery



Facilities



Technology  
& Capabilities



Case Studies



STADCO

# Development, new markets

- Russia
  - Many in-coming OEMs
    - Ford
    - VW
    - GM
    - Nissan
    - Toyota
    - Renault



Introduction



History



Our Company



Quality  
& Delivery



Facilities



Technology  
& Capabilities



Case Studies



**STADCO**

# Summary

- Stadco is a strong and growing market leader
  - Full service provider
  - Very wide product capabilities
- BIW outsourcing will remain buoyant and will continue to grow
  - Economic drivers
  - Platform derivatives growth
- Future prospects are strong
  - Geographic expansion
  - New Platforms



Introduction



History



Our Company



Quality  
& Delivery



Facilities



Technology  
& Capabilities



Case Studies



STADCO